

# DECOR-REST®

FURNITURE LTD

TOGETHER, WE FURNISH YOUR HOME WITH LOVE

# PRODUCT KNOWLEDGE

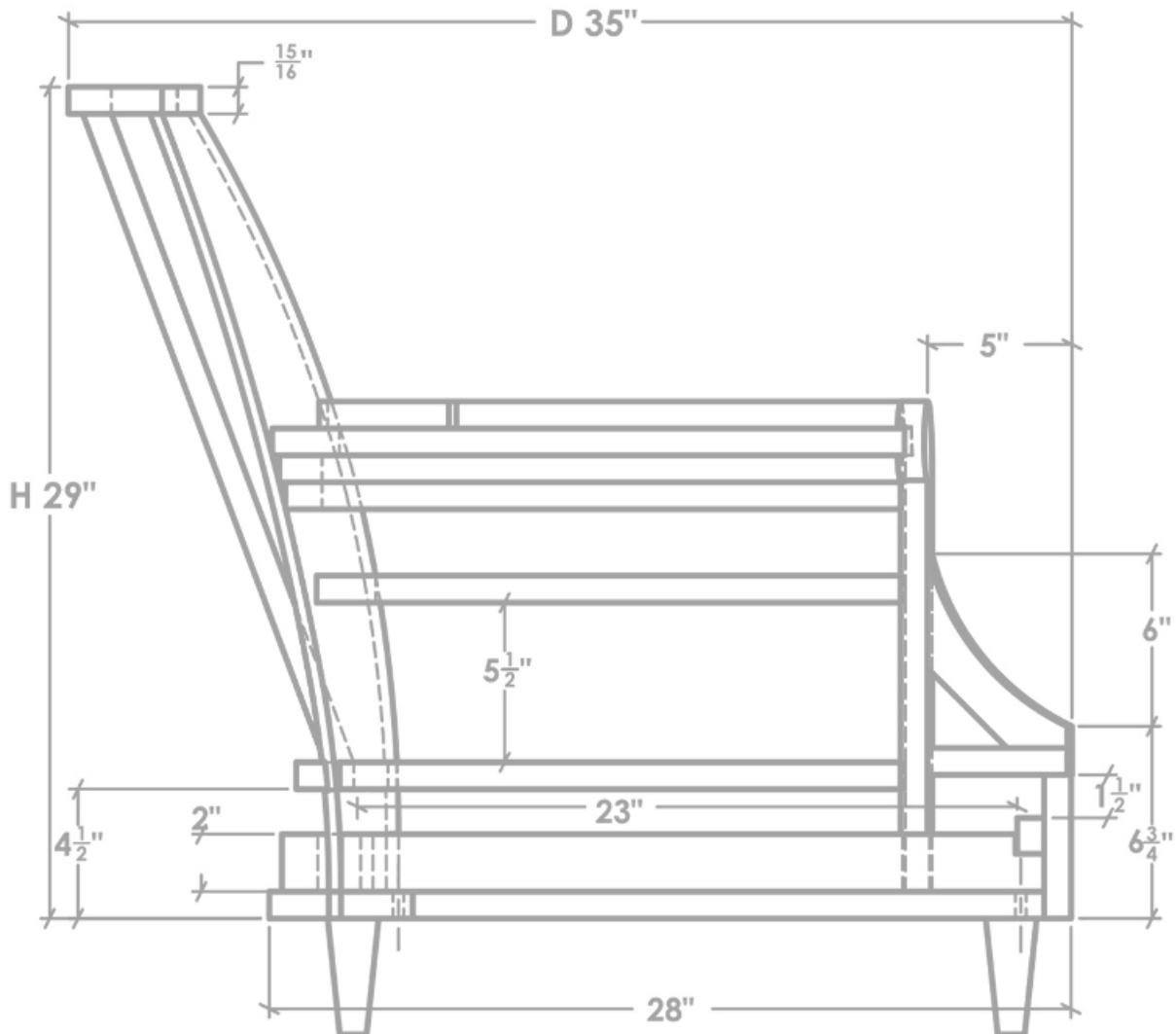

PROUDLY BUILT IN NORTH AMERICA

[www.decor-rest.com](http://www.decor-rest.com)

Check us out on Social Media!

revised: March 2021



Be  
**YOU**  
nique

MAKE IT YOURS!

# DECOR-REST®

FURNITURE LTD

## TOGETHER, WE FURNISH HOMES WITH LOVE

A world apart right here in North America, the Decor-Rest Furniture brand stands for affordably-priced, fashion-forward upholstered furniture and a compelling quality story that resonates with consumers.

A family-run company with roots in Italy and more than four decades of experience in serving retailers around the globe, we take great pride in offering the kind of furniture that will be enjoyed for years to come. Our deep-rooted values mirror those of our retail partners: We believe a beautiful and comfortable home is the foundation of a happy family, and we strive to create fresh and exciting designs that are supremely comfortable and built to last. In essence, we offer our dealers a worry-free product that both they, and their customers, can depend on.

### Award-Winning Design Excellence

We create bench-made upholstered furniture with exclusive fabrics from around the world and our upholstered designs are available for customization in hundreds of fabrics and leathers. All of our materials are applied with exquisite tailoring techniques that combine hand-cutting and design details with leading-edge technology.

Follow us on



Instagram @DecorRest



As Canada's largest stationary manufacturer with an international dealer base, the silhouettes we create in our state-of-the-art, 250,000-square-foot factory are held to a higher-standard. Our adherence to the stringent ISO 9001 Quality System results in a best-in-class construction story that is unmatched in the popular price point arena.

### Come and Grow With Us

As a leader in the international marketplace, we are laser-focused on building our business in the U.S. Market. Our steadily growing U.S. sales force is supported by dedicated U.S. customer service personnel, as well as a warehouse located in Hudson, N.C., that enables us to offer you fast fulfillment and delivery. Additionally, we provide innovative marketing support materials designed to set you apart in your marketplace.



# DECOR-REST®

FURNITURE LTD

## VISION

TO CREATE HAPPINESS IN EVERY HOME BY FURNISHING IT WITH LOVE

## MISSION

Creators of furniture; builders of relationship.  
From concept to completion it's our people's passion that makes our brand unique.

## CULTURE

Our culture is built on honesty, innovation, communication and customer driven.  
Our culture is our competitive advantage:

- We think and work as family
- We embrace honesty and caring
- We foster respect and integrity
- We encourage each other to be safe
- We are innovative
- We are customer-driven
- We are Decor-Rest

**TOGETHER, WE FURNISH HOMES WITH LOVE**



# DECOR-REST®

FURNITURE LTD

## FEATURES

## BENEFITS

### HARDWOOD FRAMES

Designed and engineered from select, air and kiln dried North American maple or birch hardwood. Corners are double-doweled, corner blocked, glued and secured with screws.

Extra support for front and back rails with **stabilizer bars** added on our sofa/loveseats

Extra centre leg (where necessary)

**BIFMA** approved and our products are **BIFMA X5.4 Standard Compliant.**

BIFMA: Business and Institutional Furniture Manufacturer's Association

### LIMITED LIFETIME WARRANTY

**Strong foundation**

**Exceptional durability!**  
**Warp free stability. Extra support for front and back rails.**

**Extra strength & support. Easy to level/move.**

This means that our furniture has endured rigorous quality testing on everything from arm strength to seating durability and stability.

### FOAM

1.9 lb. or 2.5 lb. density, premium quality. All foam is wrapped with 100% polyester fiber.

Our foams are manufactured without CFCs (chlorofluorocarbons). Fiber is fire retardant to UFAC standards. (Upholstered Furniture Action Council)



### FIVE YEAR WARRANTY ON ALL FOAM

**Combines surface softness with deep down support for great comfort.**

ALL of our styles incorporate luxurious eco-friendly foam and Decor-Rest foam consist of natural soya oils, fresh, abundant, domestically grown and sustainable, for a smaller environmental footprint.

### SINUOUS SPRINGS CONSTRUCTION

8 gauge sinuous springs, 5 springs per seat, plus a unique **SLING SPRING** on sofa/loveseats  
Inside backs are sprung with no-sag 12 gauge spring construction.  
Springs are acrylic dipped

All seating springs are attached to hardwood using polyresin clips. (20,000 PSI tested)

### LIMITED LIFETIME WARRANTY

**Extra support and comfort.**

**Avoids corrosion and squeaking.**

**Prevents metal to metal squeaking.**

### DROP-IN COIL SEATING CONSTRUCTION

Coil springs made from high carbon heat tempered spring wire. Single-coil springs are securely clinched to roll-formed, steel channel bars. Hand fabricated link-top assembly

### LIMITED LIFETIME WARRANTY

Distributes weight evenly and smoothly.

### FABRIC AND WORKMANSHIP

The combination of a traditional, hand crafted approach together with advanced technology.

Carefully selected and tested fabrics are used on leading, innovative designs.

Tailoring is skillful and precise.

Self covered and padded decks demonstrate our great attention to detail.

### ONE YEAR WARRANTY

**Superior quality products.**

**Custom made.**

**Great value to you!**  
**Adds longer life to foams and springs.**

# DECOR-REST®

FURNITURE LTD

## ADDED VALUE

### Covered Decks

Full covered decks matching the body fabric. Our decks are padded demonstrating our attention to detail.

### Zippers

Zippers are on all pillows, inside backs and seats. Seat cushions also have a home pocket for all zipper tags.

### Inside Back are Sprung for Support

All backs are also sprung with 12 gauge No-Sag sinuous springs construction!

### Sling Spring

A unique spring on either end of all sofa/loveseats provides extra support.

### Spring Clips

Springs are attached to the North American hard wood with polyresin spring clips to prevent metal on metal squeaking.



### ISO 9001 Quality Certified

As a registered company in Canada of the ISO 9001 Quality Management System, top quality in all areas of manufacturing is guaranteed.

### Stabilizer Bars In Frame

Warp free stability. Extra support for front and back rails. Exceptional durability

### Channeled Inside Backs

All our upholstery has unique channeled backs filled with siliconized fiber preventing flattening or shifting.

### Trending Color Finishes

Fruitwood, Espresso, Black, Pewter and Weathered Ivory made from 100% solid wood.

### Corners are Glued, Double-Doweled, Corner Blocked and Secured with Screws



### Eco Friendly Foams with No CFC

ALL of our styles incorporate luxurious eco-friendly foam and are manufactured without CFCs (chlorofluorocarbons), using highly resilient 1.9 lb to 2.5 lb density. Decor-Rest foam consists of natural soya oils, fresh, abundant, domestically grown and sustainable, for a smaller environmental footprint.

### Extra Padding

Arms are padded for ultra comfort.

### Outside Back, Outside Arm Webbing

Reinforced webbing suspension on outside arm and outside back of selected frames

### Sectional Connector

Metal spring loaded. Easy to use and out of sight.

### Bench Seat Clips

### Double Welts on Selected Styles

Selected styles offer contrast Welts, fringes at No Charge

### Leather or Fabric Swatch on All Items to Match Dye Lots

### Total Room Solutions with Accent on Home

From occasional tables to lamps and mirrors we have the accessories to help you coordinate your total room solution.



Decor-Rest Furniture is now BIFMA approved and our products are BIFMA X5.4 Standard Compliant. This means that our furniture has endured rigorous quality testing on everything from arm strength to seating durability and stability.

# DECOR-REST

FURNITURE LTD

## A LEADING NORTH AMERICAN MANUFACTURER OF FINE UPHOLSTERY, SINCE 1972

OUR PASSION FOR DESIGN EXCELLENCE IS EVIDENT IN EVERY PIECE OF UPHOLSTERED FURNITURE WE MANUFACTURE.

### INSIDE BACK

All our upholstery has unique channeled backs and are filled with siliconized fiber which prevents flattening or shifting.

### FABRIC AND WORKMANSHIP

We combine traditional hand crafted expertise with advanced technology. Top trending fabrics along with proven fabric winners are tested for quality and durability. Tailoring is skillful and precise on innovative designs with above industry standard warranties.

### STABILIZER BARS

Warp free stability.  
Extra support for front and back rails.  
Exceptional durability!

### ZIPPERS

Zippers are on all pillows, inside backs and seats.  
Seat cushions have a home pocket for all zipper tags.

### ARMS

Arms are padded for ultra comfort.

### SINUOUS SPRINGS BACK

All backs are also sprung with 12 gauge No-Sag sinuous spring construction!

### PILLOW

Blown dacron fiber or water fowl feather encased in a 100% cotton twill are used in all our zippered pillows.

Larger water fowl feather pillows are uniquely channeled preventing flattening or shifting.

### WEBBING

Reinforced webbing suspension on outside arm and outside back on selected styles.  
Great value to you!

### DECKS

Full covered decks in the main body fabric. Our decks are also padded demonstrating our attention to detail.

### HARDWOOD FRAMES

Designed and engineered from select, air or kiln dried North American maple or birch hardwood. Corners are double-doweled, corner blocked, glued and secured with screws.  
Extra centre leg (where necessary).

### LEG

100% Solid wood  
Color options available.

### ADDED VALUE

Large deluxe edge roll is added to hold seat cushion in place.

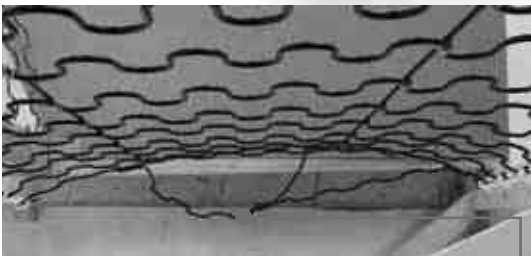

### SINUOUS SPRINGS SEATING

All seating is sprung with 8 gauge No-Sag sinuous spring construction. 5 springs per seat, **plus an unique SLING SPRING on all sofa/loveseats provides extra support.** Springs are attached to the North American hard wood with polyresin spring clips to prevent metal on metal squeaking.

### ENVIRONMENTAL GREEN SOYA FOAM



ALL of our styles incorporate luxurious eco-friendly foam and are manufactured without CFCs (chlorofluorocarbons), using highly resilient 1.9 lb to 2.5 lb density. Decor-Rest foam consist of natural soya oils, fresh, abundant, domestically grown and sustainable, for a smaller environmental footprint.

# BIFMA

BUSINESS + INSTITUTIONAL FURNITURE  
MANUFACTURERS ASSOCIATION



AS A REGISTERED COMPANY IN CANADA OF THE ISO 9001 CERTIFICATION PROGRAM, TOP QUALITY IN ALL AREAS OF MANUFACTURING IS GUARANTEED

[www.decor-rest.com](http://www.decor-rest.com)

Check us out on Social Media!



# DECOR-REST®

FURNITURE LTD

## ECO-FRIENDLY FOAM FOR YOUR HEALTHY HOME

### STANDARD SEAT CUSHION

1.9 - 2 LB. Foam - Standard Comfort with an \*ILD - (Indentation Load Deflection) of 31-37

### FIRM SEAT CUSHION

1.9 to 2 LB. Foam - Firm Comfort with an \*ILD - (Indentation Load Deflection) of 40-48

### PREMIUM SEAT CUSHIONS

Combines the finest properties of comfort, retention of shape and support with superior bounce back after severe compression.

1. 2 LB. Foam - Super Soft Comfort - Premium High-Resiliency with an \*ILD - (Indentation Load Deflection) of 16-22
2. 2.5 LB. Foam - Soft Comfort - Anti-Microbial, Bio Plush Foam with an \*ILD - (Indentation Load Deflection) of 25-31
3. 2.5 LB. Foam - Soft Comfort - Premium High-Resiliency with an \*ILD - (Indentation Load Deflection) of 22-28

\*ILD - INDENTATION LOAD DEFLECTION: is a measurement in firmness level. The higher the number, the more weight in pounds is required to compress foam 25%

### Foams that feel good and you can feel good about

CertiPUR-US® is a certification program administered by a not-for-profit organization.

#### CERTIPUR-US CERTIFIED FOAMS ARE:



- ✓ Made without ozone depleters
- ✓ Made without PBDEs, TDCPP or TCEP ("Tris") flame retardants
- ✓ Made without mercury, lead, and other heavy metals
- ✓ Made without formaldehyde
- ✓ Made without phthalates regulated by the Consumer Product Safety Commission

✓ Low VOC (Volatile Organic Compound) emissions for indoor air quality (less than 0.5 parts per million)



## WARRANTY

IS EXERCISED THROUGH YOUR RETAILER

1 YEAR	2 YEAR	3 YEAR	5 YEAR	LIFETIME LIMITED
Workmanship Fabric Mattress Metal Swivel Base Exposed Show-wood	Leather	Sofabed Mechanism  Motion Mechanism	Foam Cushion	Wood Frame Construction  Spring Construction

### SUGGESTED CARE FOR YOUR UPHOLSTERED FURNITURE

Vacuum and rotate cushions regularly.

Avoid exposure to direct sunlight.

To increase life expectancy, have your upholstery professionally cleaned.

Follow cleaning code instructions found on the fabric content label which is located under the seat.

Please visit our website for complete details about fabric care.

[www.decor-rest.com](http://www.decor-rest.com)



VPC Group



# DECOR-REST<sup>®</sup>

FURNITURE LTD



**CertiPUR-US<sup>®</sup>** is a program of the Alliance for Flexible Polyurethane Foam Inc. In order to meet the exacting standards of the program, foam products are examined and put through a series of scientific tests, by internationally accredited, independent laboratories. The CertiPUR-US<sup>®</sup> standard was created in response to consumer demand for product safety standards and particularly in response to substandard foams and consumer concerns about indoor air quality. The CertiPUR-US<sup>®</sup> seal provides confidence that certified foam products have been tested and meet durability, comfort and emission standards for both manufacturers and consumers.

## Quality and Safety Certified Foam Products that You Can trust

- » Low emission (VOCs) for improved indoor air quality.
- » Made without mercury, lead, heavy metals, formaldehyde, or ozone depleters. (no CFCs)
- » Made without methylene chloride, PBDEs or prohibited phthalates.
- » Evaluation of foam content and important durability factors.
- » Great marketing potential.

For more information contact:  
VPC Group Inc.  
150 Toro Road, Toronto, ON. M3J 2A9  
Tel: 416 630 6633 | Fax: 416 630 9921  
www.vpcgroup.com | info@vpcgroup.com

Proudly Made in Canada

BioPlush<sup>™</sup>

100% Green 100% Safe



TM are trademarks of VPC Group Inc. and are also denoted in bold type.  
Copyright © 2016. Entire contents copyright VPC Group Inc. All rights reserved.

# BioPlush™

*Better for you. Better for life.*



**BioPlush™** replaces a portion of its fossil fuels based ingredients with natural seed-based oils such as soybeans in the manufacturing process. The use of BioPlush™ can help decrease the dependence on fossil fuels and lessens greenhouse gas emissions. **BioPlush™** has the same high comfort and performance as VPC Group Inc.'s traditional foams, yet delivers a smaller environmental footprint by offering lower CO2 emissions and energy requirement through the replacement of petroleum-based ingredients. VPC Group Inc. believes all practices that help reduce our carbon footprint are a positive step.

## Sustainable Environmentally Conscious Product without any loss In Product Performance

- » Low odour emissions.
- » Less dependences on nonrenewable resources.
- » Reducing carbon footprint.
- » Great comfort level and exceptional hard-feel.
- » For every million pounds of petroleum-based polyols replaced with bio polyols, nearly 2,200 barrels of crude oil can be saved.

For more information contact

**VPC Group Inc.**

150 Toro Road, Toronto, ON. M3J 2A9

Tel: 416 630 6633 | Fax: 416 630 9921

www.vpcgroup.com | info@vpcgroup.com

TM are trademarks of VPC Group Inc. and are also denoted in bold type.  
Copyright © 2016. Entire contents copyright VPC Group Inc. All rights reserved.

Proudly Made in  Canada

**BioPlush**  
*How it's made. How it's life.*

Environmentally Sustainable



Includes Plant Material

Ozone Friendly Manufacturing



Zero CFC Process



# reserve

L U X U R Y B Y

**DECOR-REST**  
FURNITURE LTD

## DROP-IN COIL SEATING CONSTRUCTION

- Coil springs made from high carbon heat tempered spring wire and designed to meet the customers demand for seating comfort.
- Units are customized to fit into each frame.
- Securely fastened to the hardwood frames with screws.
- Single-coil springs are securely clinched to roll-formed, steel channel bars.
- Hand fabricated link-top assembly distributes weight evenly and smoothly.
- Steel bars to support each coil.
- Made in the USA



## PREMIUM SEAT CUSHIONS

- 2.5 LB. Foam - Soft Comfort - Premium High-Resiliency with an \*ILD - (Indentation Load Deflection) of 22-28

\*ILD - Indentation Load Deflection: is a measurement in firmness level. The higher the number, the more weight in pounds is required to compress foam 25%

- Combines the finest properties of comfort, retention of shape and support with superior bounce back after severe compression.



## NO LIMITATIONS

- All Body and Pillows fabrics are inclusive



# DECOR-REST®

FURNITURE LTD

## SOFABED MATTRESS

### POSTURE CARE LUXURY SLEEP SYSTEM

#### FEATURES | BENEFITS

<p>Available in CANADA AND U.S.A</p>	<p><b>MEMORY GEL FOAM MATTRESS</b> 5" all foam mattress 2.5", 1.9 lb Base 2.5" 3 lb MEMORY GEL TOPPER No Flip...Weltd with lining on the bottom</p>	<p>Provides support and comfort by molding to your body while in use. Sleeps 1-2 degrees cooler than traditional memory foam</p>
<p>Available in CANADA</p>	<p><b>STANDARD MATTRESS</b> Queen: 308 coil count density Double: 264 coil count density Layers of soft foam</p>	<p>Great value!</p>
	<p><b>Standard Mattress:</b> Tempered coil springs</p>	<p>Very durable for the firm support your body needs.</p>
	<p><b>Standard Mattress</b> Damask Ticking ****Multi-quilted top</p>	<p>Beautiful, long lasting imported woven damask. Very attractive, and enhances surface comfort.</p>
	<p><b>Standard Mattress:</b> Firm, uni-deck padding</p>	<p>Provides deep-down support. One year warranty.</p>
	<p><b>SOFABED MECHANISM</b> * Television headrest **Tuck-in feature ***Polypropylene deck</p>	<p>Durable! Three year warranty. Comfortable for sitting upright Blankets or sheets can be tucked in. Decking for more support</p>



\*Television Headrest



\*\*Tuck-In Feature



\*\*\*Polypropylene Deck



\*\*\*\*Multi-Quilted Top



# DECOR-REST®

FURNITURE LTD

## MEMORY GEL FOAM MATTRESS

Available in CANADA and U.S.A



5" all foam mattress

2.5", 1.9 lb Base

2.5" 3 lb MEMORY GEL TOPPER

No Flip...Weltd with lining on the bottom

Memory gel foam is temperature sensitive foam that provides support and comfort by molding to your body while in use. It returns to original state after use. The mattress will fold into the sofa the same way as a coil mattress but WILL return to its original state. Dust mite resistant and hypo allergenic. This eliminates the uncomfortable pressure points and motion transfer common to innerspring designs. MEMORY GEL TOPPER sleeps 1-2 degrees cooler than traditional memory foam.

# DECOR-REST®

FURNITURE LTD

## FABRIC CODES... and why they exist?

Decor-Rest Furniture travels the world looking for beautiful fabrics that will provide many years of satisfaction to the end consumer. When analyzing fabrics we ensure that they meet not only N. A. standards but Decor-Rest Furniture standards for durability and color fastness.



Each frame created by Decor-Rest is scrutinized and analyzed intensely to diagnose how a fabric will live on the frame. One of the greatest areas of analysis is if the fabric will move or stretch once applied to the frame, not just in the first year but for many years to come. If the frame design lends itself to movement over time, Decor-Rest will restrict fabrics where a slight movement in the fabric will weaken the overall appearance. An example of this would be a chaise as the frame, with a striped fabric. If there is a chance that in a year or two the fabric may move slightly enabling the stripe to appear 'wobbly' the end consumer will be dissatisfied. We will therefore not put a stripe on a chaise.

To ensure that the sales associate on the floor can quickly provide the necessary information on fabric to frame compatibility Decor-Rest Furniture has placed:

1. Fabric codes on each fabric swatch label.
2. Fabric codes for each frame in the price book under FEATURES.

This will take away the guess work for the sales associates, ensuring the fabric to frame compatibility. Confident sales people can now close all sales knowing the customer will not come back in one or two years with complaints regarding their fabric choice.

**For clarity please review our Fabric Codes and what they mean.**

A	ALL OVER	54"		54"		
C	CENTER					
S	STRIPE					
P	PLAID					
UTR	UP THE ROLL					
RR	RAIL ROADED					
XX	OCCASIONAL CHAIRS ONLY					
XXX	PILLOWS ONLY					

If you need further discussion on this topic please consult the Decor-Rest Sales Representative for your store. We remain 100% committed to valued partners and in partnership with them remain focused on a happy end consumer.

# DECOR-REST<sup>®</sup>

FURNITURE LTD

## FABRIC LABELS... what does it all mean?

Pattern name → Pattern/patron: **Alijon**

Pattern color → Color/couleur: **Espresso**

Pricing indicator → Grade/niveau: **38**

Must match this code to upholstery piece.  
Info found in price list → Fabric Code/Code de tissu: **FAB-A/Plain - RR**

Fabric durability → Double rubs: **25,000**

Used for fabric color organization → Color code: **60 - Espresso**

Fabric content → Fabric content/Contenu de tissu: **POLYESTER 100% POLYESTER**

See page 12 for cleaning code explanation → Cleaning code/code de nettoyage: **W**

Barcode → 

# DECOR-REST<sup>®</sup>

FURNITURE LTD



# DECOR-REST®

FURNITURE LTD

## FABRIC CLEANING CODES

**Cleaning Codes:**  
**W:** Water-Based Cleaner  
**S:** Solvent Cleaner  
**WS:** Water/Solvent Cleaner  
**X:** Vacuum Only



### Fabric Cleaning Codes

Many people do not realize that their furniture can have a longer life if they follow some very simple cleaning instructions. The Fabric Cleaning Code located under the seat cushions or bottom of furniture determines the best and least expensive method of home cleaning for your furniture.

### Water-Based Cleaner

To prevent dirt build-up, clean your furniture using a vacuum or light brush. To clean stains, use the foam only from a water-based cleaning agent such as a mild detergent or non-solvent upholstery shampoo. Be sure to apply the foam with a soft brush in a circular pattern and vacuum the area when dry. Try pre-testing a small area before proceeding. If you cannot remove the soiling or stain, be sure to use a professional furniture cleaning service.

### Solvent Cleaner

To prevent dirt build-up, clean your furniture using a vacuum or light brush. To clean stains, always use a mild water-free solvent or dry cleaning product. Be sure to clean your furniture in a well-ventilated room and avoid any products containing toxic materials. Be sure to pre-test a small area before cleaning the entire surface. If problems result, contact a professional furniture cleaning service.

### Water/Solvent Cleaner

To prevent dirt build-up, clean your furniture using a vacuum or light brush. To clean stains, be sure to use a mild solvent, an upholstery shampoo or the foam from a mild detergent. When using a solvent or dry cleaning product, always follow the instructions, clean only in a well-ventilated room and avoid any product containing toxic materials. Again, be sure to pre-test a small area before cleaning the entire surface and contact a professional furniture cleaning service if the stain persists.

### Vacuum Only

This fabric should be cleaned using a vacuum or light brush only. Water-based foam cleaners or solvent-based cleaning agents may cause excessive shrinking, staining or other damage and should always be avoided.

These guidelines have been developed by professional furniture specialists. However, there is no guarantee these tips will always be successful so use them at your own discretion. When in doubt, consult with a professional cleaning service.

**NOTE:** When pre-testing always use the bottom outside back area.





# PERFORMANCE FABRICS

Welcome to a new era in style and outstanding fabric performance! Decor-Rest Performance Fabrics are highly stain-resistant, moisture repellent, extremely durable and easy to clean. Thanks to advances in technology, these durable, high-quality fabrics are also breathable and soft to the touch for long-lasting comfort.

- ❖ Liquid Repellent
- ❖ Stain Resistant
- ❖ Moisture Management
- ❖ Breathable
- ❖ No Sacrifice on Softness
- ❖ Extremely Durable
- ❖ Easy to Clean

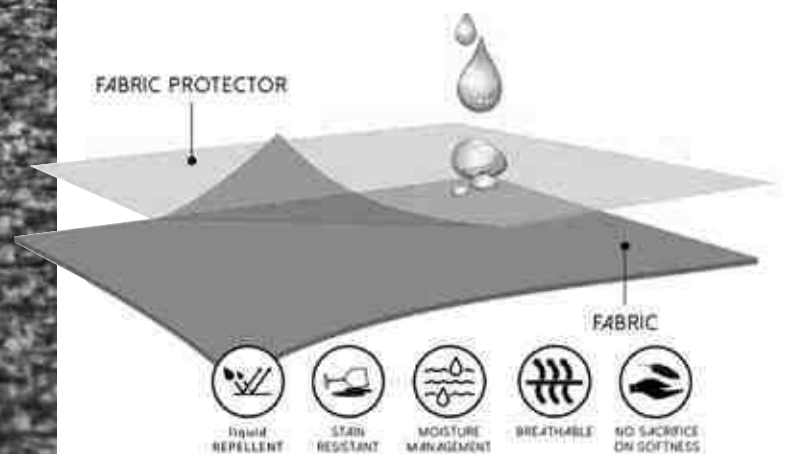

**DECOR-REST®**  
FURNITURE LTD

# DECOR-REST®

FURNITURE LTD

## NATURAL & MAN-MADE FIBERS

Blending of different fibers is done to enhance the performance and improve the aesthetic qualities of fabric. Fibers are selected and blended in certain proportions so the fabric will retain the best characteristics of each fiber. Blending can be done with either natural or manufactured fibers, but is usually done using various combinations of manufactured fibers or manufactured and natural fibers.

NATURAL FIBERS	DESCRIPTION	CHARACTERISTICS
<b>COTTON</b>	Soft, cream colored cellulose fiber from the cotton plant. Cotton is strong, sturdy, and the most versatile of the four natural fibers.	<ul style="list-style-type: none"> <li>• Comfortable/Soft hand/Absorbent/Good strength</li> <li>• Machine-washable, dry-cleanable</li> <li>• Good color retention, prints well</li> <li>• Drapes well/Easy to handle and sew</li> </ul>
<b>LINEN</b>	Crisp, beige colored cellulose fibers from flax used with fiber blends in upholstery to give a textured look.	<ul style="list-style-type: none"> <li>• Comfortable/Crisp hand/Tailors well/ Absorbent</li> <li>• Hand-washable or dry-cleanable</li> <li>• Good strength, twice as strong as cotton</li> <li>• Dyes and prints well</li> <li>• Lightweight to heavyweight</li> <li>• No static or pilling problems</li> <li>• Fair abrasion resistant</li> </ul>
<b>SILK</b>	Fine, strong, shiny protein fiber made from the silk-worm to spin the cocoon. It is used infrequently due to cost.	<ul style="list-style-type: none"> <li>• Soft or crisp hand/Luxurious</li> <li>• Drapes and tailors well</li> <li>• Thinnest of all natural fibers</li> <li>• Dyes and prints well</li> <li>• Hand-washable or dry-cleanable</li> <li>• Little problem with static, no pilling</li> <li>• Only fair abrasion resistance</li> <li>• Poor resistance to prolonged exposure to sunlight</li> </ul>
<b>WOOL</b>	Soft, bulky protein fiber from the fleece of sheep, or angora and cashmere goats. Specialty fibers come from alpaca, camel, lama and vicuna. It is used infrequently due to cost.	<ul style="list-style-type: none"> <li>• Comfortable/Versatile/Good insulator/Washable</li> <li>• Luxurious/ Soft hand</li> <li>• Lightweight/Wrinkle-resistant</li> <li>• Absorbent/Easy to dye</li> </ul>

SYNTHETIC FIBERS	DESCRIPTION	CHARACTERISTICS
<b>ACETATE</b>	Made from cellulose; has a luxurious look and feel. Acetate requires special dyes, but colors are permanent. Very economical, yet looks like silk blended with other fibers.	<ul style="list-style-type: none"> <li>• Luxurious appearance/Crisp or soft hand</li> <li>• Wide range of colors; dyes and prints well</li> <li>• Excellent drape ability and softness</li> <li>• Shrink, moth, and mildew resistant</li> <li>• Low moisture absorbency, relatively fast drying</li> <li>• No pilling problem, little static problem</li> <li>• Most acetate garments require dry-cleaning</li> </ul>
<b>ACRYLIC</b>	The most natural of the man-made fibers, it is soft, warm, light weight and is used to make many of today's soft plush or fur-like fabrics.	<ul style="list-style-type: none"> <li>• Light-weight, soft, warm with a wool-like hand</li> <li>• Dyes to bright colors with excellent fastness</li> <li>• Machine washable, quick drying</li> <li>• Resilient-retains shape; resists shrinkage &amp; wrinkles</li> <li>• Flexible aesthetics for wool- or cotton-like blended appearance</li> <li>• Resistant to moths, oil and chemicals</li> <li>• Superior resistance to sunlight degradation</li> <li>• Static and pilling can be a problem</li> </ul>
<b>NYLON</b>	Smooth, lustrous and the strongest of all fibers. It can be made into smooth flat, shiny fabrics, pile fabrics, or textured fabrics.	<ul style="list-style-type: none"> <li>• Lightweight/Exceptional strength</li> <li>• Good drape ability/Abrasion resistant</li> <li>• Easy to wash</li> <li>• Resists shrinkage and wrinkling</li> <li>• Resilient, pleat retentive</li> <li>• Fast drying, low moisture absorbency</li> <li>• Can be pre-colored or dyed in a range of colors</li> <li>• Resistant to damage from oil and many chemicals</li> <li>• Static and pilling can be a problem</li> <li>• Poor resistance to continuous sunlight</li> </ul>
<b>OLEFIN</b>	The lightest in weight of all man-made fibers providing good bulk and surface coverage.	<ul style="list-style-type: none"> <li>• Lightweight, lightest fiber, it floats</li> <li>• Strong / Abrasion resistant, resilient</li> <li>• Stain, static, sunlight, and odor-resistant</li> <li>• High insulation characteristics</li> <li>• Resists deterioration from chemicals, mildew, perspiration, rot and weather</li> <li>• Fast drying</li> <li>• Spills can be readily wiped up</li> <li>• Static and pilling can be a problem</li> </ul>
<b>POLYESTER</b>	Soft, lightweight fiber with great strength and good resistance to abrasion. It has been used successfully in easy-to-care upholstery fabrics.	<ul style="list-style-type: none"> <li>• Strong/Resistant to stretching and shrinkage</li> <li>• Washable or dry-cleanable/Quick drying</li> <li>• Resilient, wrinkle resistant, excellent pleat retention</li> <li>• Abrasion resistant</li> <li>• Resistant to most chemicals</li> </ul>
<b>RAYON</b>	The first of the man-made fibers, it is almost pure cellulose, and is soft and comfortable with a good feel. It looks like silk when combined with other fibers, and is easy to clean.	<ul style="list-style-type: none"> <li>• Soft and comfortable</li> <li>• Drapes well</li> <li>• Highly absorbent</li> <li>• Dyes and prints well</li> <li>• No static, no pilling problems</li> <li>• Fabric can shrink appreciably if washing</li> </ul>

# DECOR-REST<sup>®</sup>

F U R N I T U R E L T D

## LEATHER CARE

By regularly cleaning and caring for your leather upholstery, your furniture can maintain its beautiful luster and give you a lifetime of enjoyment. If you want to ensure its longevity, here are a few important tips you should keep in mind when caring for leather.

Always be sure to protect your leather from fading or drying. This means keeping leather furniture away from direct sunlight if possible and making sure your home is humidified during those cold winter months. Although treated leathers can resist sunlight, no material is totally impervious to fading so try rearranging your furniture on occasion to avoid potential sun damage.

Spills might ruin your clothes but that doesn't mean they have to ruin your furniture. Take care of spills immediately with a clean cloth and try blotting out the spill rather than pressing. Most spills will blot up without a trace. However, if the spill penetrates the leather, gently massage it with a clean cloth dampened with distilled water.

Cleaning your leather routinely with a clean damp cloth will help eliminate oils that can build up and easily discolor your leather or break down its protective coating.

Frequent dusting is the best way to clean most leathers. Be sure to dust all leathers carefully using a vacuum cleaner with a soft brush attachment.

If your leather becomes damaged by difficult stains such as gum, grease or red wine, don't try to clean it yourself. Call your professional leather cleaner for further assistance.

# DECOR-REST®

F U R N I T U R E L T D

## LEATHER GLOSSARY

### **FULL-GRAIN** (versus plated, embossed, buffed or corrected leather)

This is the term for the leather surface without an attempt to hide or conceal the natural markings of the animal which it incurred during its lifetime. Life leaves its traces on cattle in the forms of healed scratches, insect bites, blood veins, growth wrinkles, and variation of grain, all of which constitute the character and charm of “Nature’s Signatures.” Full-grain leather can be either pure aniline or semi-aniline (or aniline-plus). It is sometimes plated to produce a special effect or even to enhance an already natural grain, such as a textured appeal versus a smooth appeal.

### **TOP-GRAIN** (versus split leather)

The thickness of all hides before tanning can vary quite a bit. To obtain a uniform thickness for upholstery, the hides are fed through a splitting machine with the grain side up, yielding a grain portion called “top-grain.” The underneath or flesh layer that is cut off is called a “split.”

### **PLATED, EMBOSSED, BUFFED or CORRECTED** (versus full-grain leather)

When full-grain leather has too many of “Nature’s Signatures,” it is buffed or sanded much in the same manner as wood is sanded. The sanding or correcting process levels the high spots of healed scratches, etc., and removes some of the natural grain. A grain pattern is then embossed into the surface to replace what was lost in the sanding process. Plated leather is usually aniline-plus (or semi-aniline). **SPLIT** (versus top-grain leather) no natural grain. The tissue structure is not as strong as top-grain and is generally not recommended for the seating area of upholstery, due to this lack of tissue strength.

### **FULL or PURE ANILINE** (versus semi-aniline or aniline-plus leather)

It is generally accepted that only five percent of the world’s hide supply is of high enough quality for pure aniline upholstery furniture. Aniline dyeing is the process of soaking the skins in transparent aniline dyes, which color or shade the skins without obscuring the natural markings or grain character of the leather. The hides are dyed all the way through, with no pigmented topcoat.

### **SEMI-ANILINE or ANILINE-PLUS** (versus full or pure aniline leather)

These are terms that define a supplemental step beyond aniline dyeing, which adds a topcoating of highly dispersed pigments and dyes to the surface of aniline-dyed hides. By dyeing the leather throughout before the final surface coating, a very even coloration can be achieved with only a thin layer of finish, and the leather remains softer.

# DECOR-REST®

FURNITURE LTD

## ADDITIONAL PILLOWS

Grade of fabric dictates price. Please see pillow page near the end pages in the price list.



### MEASURING GUIDE

\*Slightly stretch out corners and measure end to end.

PILLOW SIZE	DESCRIPTION	FILLING	FILLING DESCRIPTION	
			FEATHER	DACRON
18" X 18" 20" X 20" 22" X 22" 24" X 24"	Square with NO Welt OR Square - with Welt	Dacron OR Feather	Water fowl feather encased in a 100% cotton twill	Made from 100% Polyester for superior resiliency
KIDNEY SIZE	Rectangular with NO Welt OR Rectangular - with Welt			
21" X 13" 22" X 11" 23" X 16"				

Pillows should be fluffed periodically to ensure fullness and longevity.

## FINISH PRODUCT MEASURING GUIDE

(Dimensions may vary ±1")

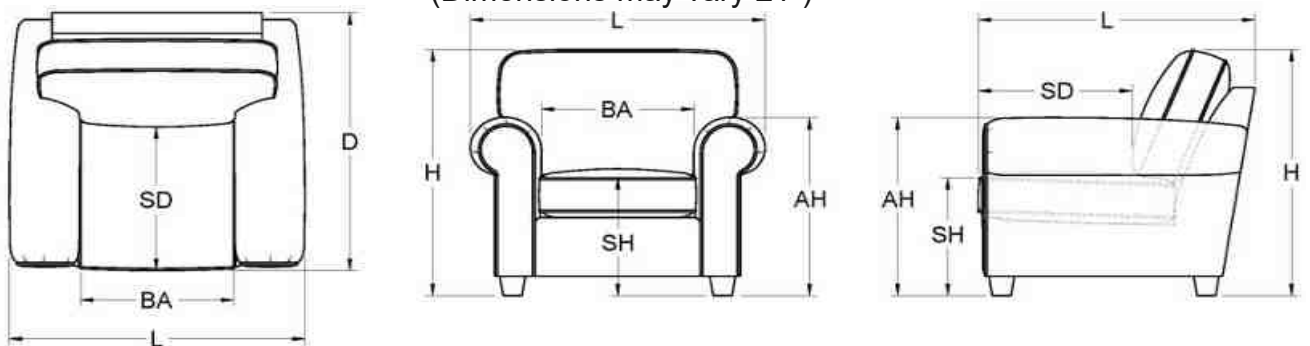

AH: arm height SD: seat depth SH: seat height BA: between arms

# DECOR-REST®

FURNITURE LTD

## PARTS LIST

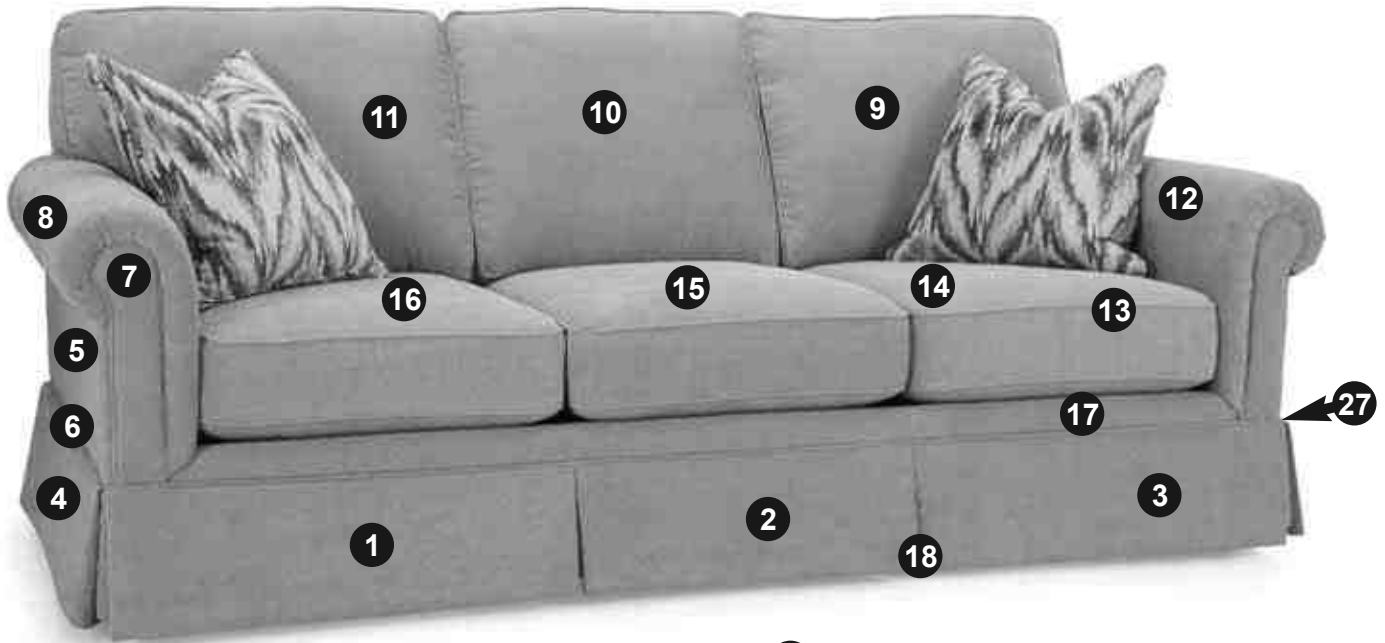

- |                                  |                                    |                                     |
|----------------------------------|------------------------------------|-------------------------------------|
| 1. Left hand facing skirt        | 11. Left hand facing inside back   | 21. Inside back                     |
| 2. Centre skirt                  | 12. Right hand facing inside arm   | 22. Top band                        |
| 3. Right hand facing skirt       | 13. Piping/Welt                    | 23. Top band pull                   |
| 4. Side skirt (Left or Right)    | 14. Right hand facing seat cushion | 24. Outside back                    |
| 5. Left hand outside arm         | 15. Centre seat cushion            | 25. Back arm facing (Left or Right) |
| 6. Piping/Welt                   | 16. Left hand facing seat cushion  | 26. Outside back skirt              |
| 7. Facing (Left or Right)        | 17. Edge                           | 27. Right hand outside arm          |
| 8. Left hand facing inside arm   | 18. Flap                           | 28. Leg                             |
| 9. Right hand facing inside back | 19. Bottom band                    |                                     |
| 10. Centre inside back           | 20. Seat Band                      |                                     |





Be  
**YOU**  
nique

MAKE IT YOURS!





Follow us on



Instagram @DecorRest

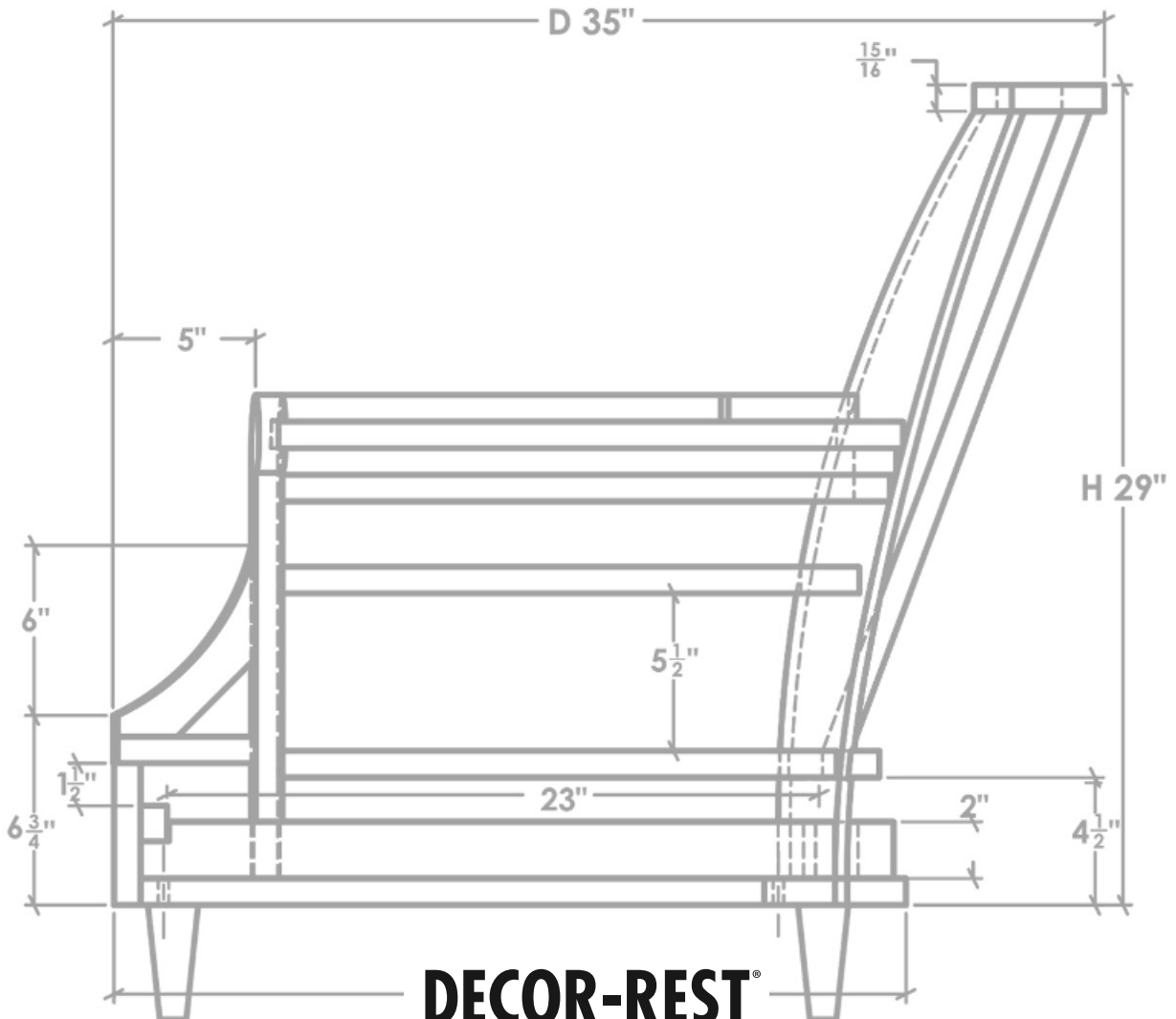

**DECOR-REST**<sup>®</sup>  
FURNITURE LTD

TORONTO - HIGH POINT - LAS VEGAS

[www.decor-rest.com](http://www.decor-rest.com)